

# **S102 WiFi / BT / GNSS Module**

## **Product Specification**

**802.11a/b/g/n/ac 2.4G & 5G & BT & GNSS Module**

**(Hi1102A V100)**

**Version Ver1.0**

### **History**

<b>Document Release</b>	<b>Date</b>	<b>Modification</b>	<b>Initials</b>	<b>Approved</b>
Version V1.0	2023/04/03			

# S102 WiFi / BT / GNSS Module

---

## 1、Characteristic

Hi1102A is a highly integrated high-power SoC chip that provides a wireless communication solution for applications in smart terminals, including WLAN, Bluetooth, and GNSS functionalities.

Hi1102A integrates the following functions on a single chip:

- WLAN (2.4GHz and 5GHz, supporting IEEE 802.11a/b/g/n/ac and narrowband characteristics) MAC+PHY +ABB+RF
- Bluetooth (BR/EDR and BLE, supporting 5.1/5.0/4.1/4.0/2.1) Baseband+RF
- GNSS (supporting GPS/Glonass/BeiDou/Galileo/QZSS) Baseband + RF

### 1.1 Characteristics of WLAN

The Characteristics of WLAN are as follows:

- Supports WLAN frequencies globally(2.4GHz:2412MHz ~ 2484MHz; 5GHz:4.9GHz ~ 5.9GHz).
- 2.4GHz supports 20/40 MHz bandwidth,PHY 150Mbit/s@HT40 MCS7,200Mbit/s@VHT40 MCS9.
- 2.4GHz frequency band supports Channel 1~13.
- 5GHz supports 20/40/80 MHz bandwidth, with a maximum PHY throughput of 433Mbit/s.
- 5GHz frequency band supports 4.9GHz~5.9GHz.
- Integrated WiFi TX/RX Balun for 2.4GHz, with built-in PA and Switch, does not support external FEM.
- Integrated WiFi TX/RX Balun for 5GHz, does not integrate PA, supports external FEM.
- Supports STA mode and AP mode.
- In AP mode, supports up to 8 STAs and supports mixed mode access.
- Supports SDIO3.0, with a maximum clock frequency support of 208MHz, typical value is 192MHz.
- Supports concurrent STA and P2P.
- STA security, supports WEP, WPA, WPA2, WPA3, CKIP, WPS/WPS2.0, EAP.
- AP security, supports WPA2, WPA3.
- Supports roaming.
- Supports WiFi Direct for high-speed P2P connections.
- Supports WiFi Display (requires Android/HarmonyOS upper layer).

### 1.2 Characteristics of Bluetooth

The characteristics of Bluetooth are as follows:

- Supports Headset and Handsfree.
- Supports A2DP (Audio Distribution).
- Supports AVRCP Audio/Video Remote Control Protocol.
- Supports HID Human Interface Devices.
- Supports up to 7 ACL links concurrently.
- Supports BT and BLE.
- Transmit power supports Class1 (10dBm).
- Supports WBS.
- Certified through BQB testing.
- Supports WLAN and Bluetooth coexistence.

### 1.3 Characteristics of GNSS

The characteristics of GNSS are as follows:

- Supports GPS L1, Glonass, Beidou, Galileo E1, QZSS, etc.
- Supports concurrent searching, tracking, and positioning of various satellite systems.
- Supports Standalone positioning.
- Supports GPS, Glonass, Beidou, and Galileo four-mode PVT positioning solutions.
- Supports external time synchronization.

# S102 WiFi / BT / GNSS Module

## 1.4 Module block diagram

The Hi1102A mainly includes five modules: PMU, CMU, Always On subsystem, WLAN SoC subsystem, and BFGI SoC subsystem.

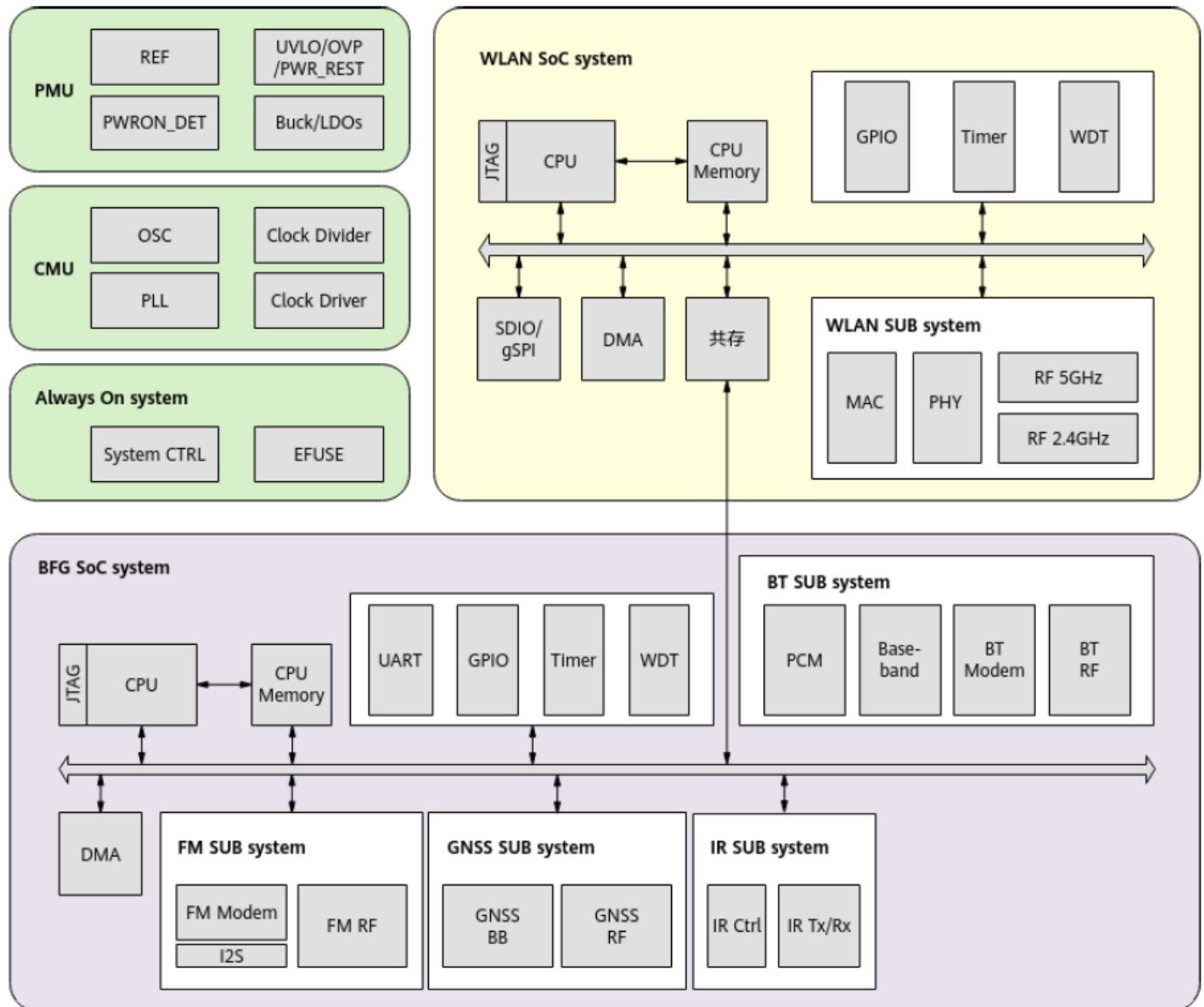

## 1.5 Key electrical characteristics.

The electrical characteristics are as follows:

- Chip supports input voltage range: 3.5V to 4.5V.
- Chip supports digital I/O voltage of 1.8V.
- Packaged in FCCSP, dimensions 5.8mm x 5.1mm x 0.85mm.
- Operating temperature: -30°C to +85°C.
- Junction temperature: <105°C.

## 1.6 Application areas.

- Smartphones
- PAD
- Data cards
- PDA
- Wearable devices
- Drone transmission images.

# S102 WiFi / BT / GNSS Module

## 2、Module size (Units: mm)(tolerance $\pm 10\%$ )

(Note: Without shield cover, module height is around 1.8mm, including chip + PCB board thickness)

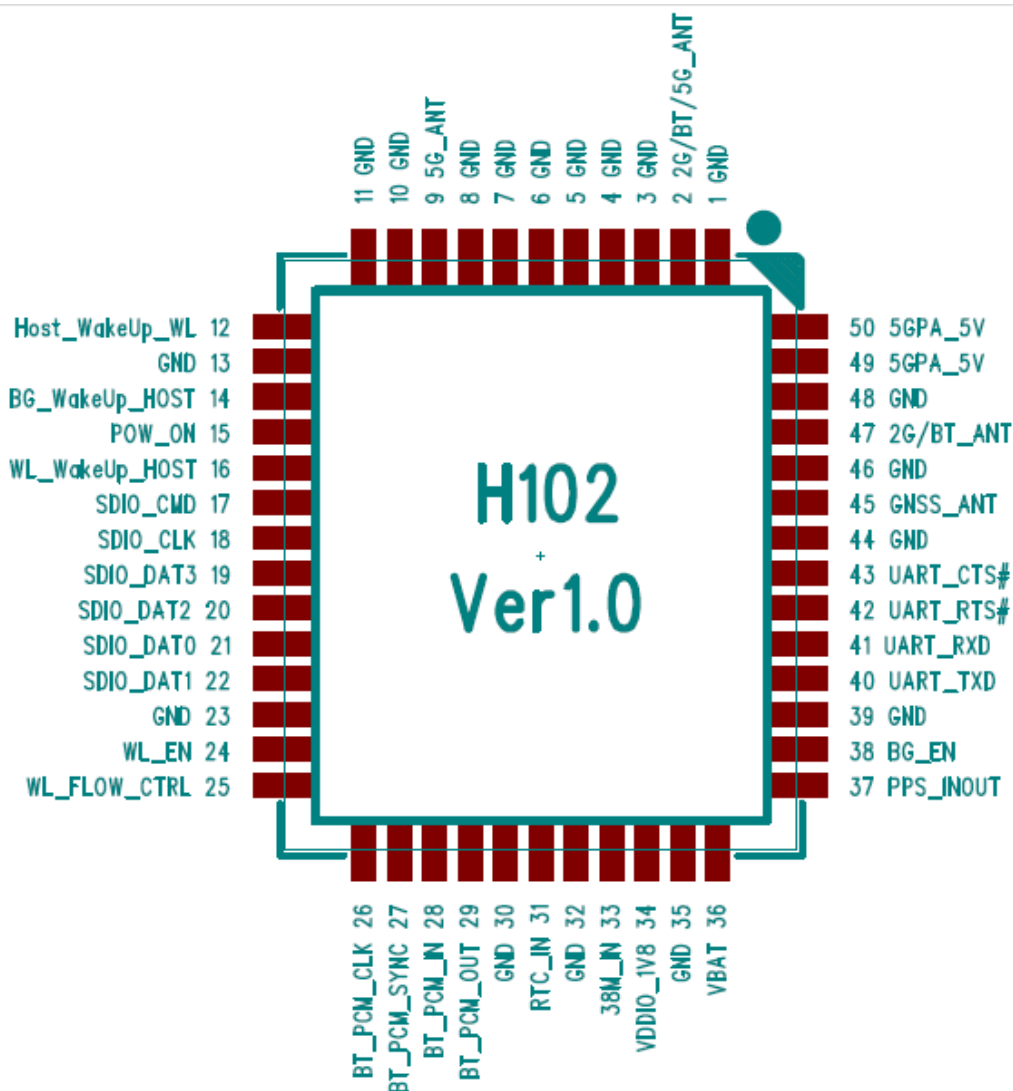
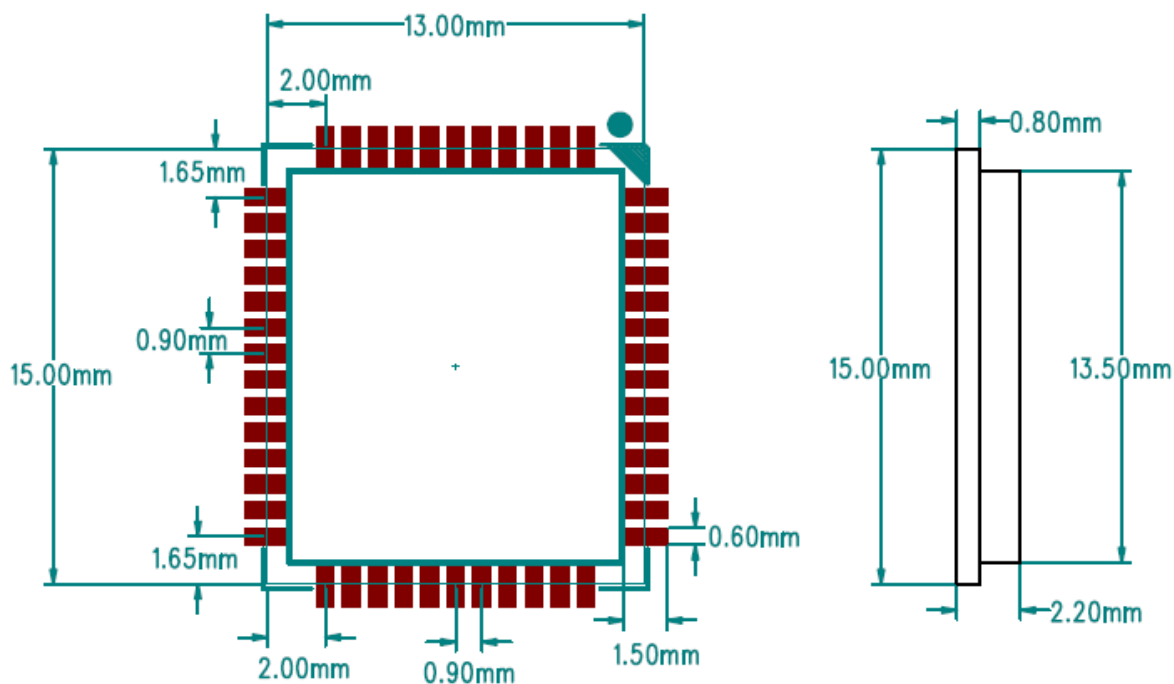

# S102 WiFi / BT / GNSS Module

## 2.1 Module Pin Definition

Pin	Function	Type	Voltage	Description
1	GND	GND	-	GND
2	2G/BT/5G_ANT	IORF	-	WLAN 2G/BT/5G RF Input/Output (Note 1)
3	GND	GND	-	GND
4	GND	GND	-	GND
5	GND	GND	-	GND
6	GND	GND	-	GND
7	GND	GND	-	GND
8	GND	GND	-	GND
9	5G_ANT	IORF	-	WLAN RF 5G Input/Output (Note 2)
10	GND	GND	-	GND
11	GND	GND	-	GND
12	Host_WakeUp_WL	I	1.8V	Host_WakeUp_WL (also a chip configuration pin, should not be high during power-up)
13	GND	GND	-	GND
14	BG_WakeUp_HOST	O	1.8V	BT/GNSS_WakeUp_HOST
15	POW_ON	I	1.8V	Hi1102A power-on enable signal, active high.
16	WL_WakeUp_HOST	O	1.8V	WL_WakeUp_HOST
17	SDIO_CMD	I/O	1.8V	SDIO Command In
18	SDIO_CLK	I/O	1.8V	SDIO CLK
19	SDIO_DAT3	I/O	1.8V	SDIO Data3
20	SDIO_DAT2	I/O	1.8V	SDIO Data2
21	SDIO_DAT0	I/O	1.8V	SDIO Data0
22	SDIO_DAT1	I/O	1.8V	SDIO Data1
23	GND	GND	-	GND
24	WL_EN	I	1.8V	WL_EN
25	WL_FLOW_CTRL	I	1.8V	Used to control WiFi data flow,improve SDIO throughput, enabled by algorithm decision, enable this pin when flow control is needed, active low
26	BT_PCM_CLK	I/O	1.8V	BT_PCM_CLK
27	BT_PCM_SYNC	I/O	1.8V	BT_PCM_SYNC
28	BT_PCM_IN	I	1.8V	BT_PCM_IN
29	BT_PCM_OUT	O	1.8V	BT_PCM_OUT
30	GND	GND	-	GND
31	RTC_IN	I	-	Module external 32.768KHz crystal or single-ended 32.768KHz signal input
32	GND	GND	-	GND
33	38M_IN	I	-	Reserved for external 38MHz TCXO crystal signal input, already available on module, can be left floating.
34	VDDIO_1V8	IPMU	1.8V	VDDIO power supply input voltage fixed at 1.8V
35	GND	GND	-	GND
36	VBAT	IPMU	3.7V	VABT power supply input voltage range 3.5~4.5V, typical value 3.7V
37	PPS_INOUT	I	1.8V	GNSS second pulse signal input
38	BG_EN	I	1.8V	BT/GNSS_EN
39	GND	GND	-	GND
40	UART_TXD	O	1.8V	UART Transmit output, internally pulled up in Hi1102A.
41	UART_RXD	I	1.8V	UART Receive input, Host configuration requires internal pull-up.
42	UART_RTS#	I/O	1.8V	UART Request To Send (active low), internally pulled up in Hi1102A.
43	UART_CTS#	I/O	1.8V	ART Clear To Send input (active low), Host configuration requires internal pull-up.
44	GND	GND	-	GND
45	GNSS_ANT	IORF	-	GNSS RF input (Note 4)
46	GND	GND	-	GND
47	2G/BT_ANT	IORF	-	WLAN 2G/BT RF Input/Output (Note 3)
48	GND	GND	-	GND
49	5GPA_5V	IPMU	5V	5G FEM power supply input voltage 5V
50	5GPA_5V	IPMU	5V	5G FEM power supply input voltage 5V

# S102 WiFi / BT / GNSS Module

## Note: Explanation of S102 Module Antenna Options

Option 1: 2.4G/5G uses a single antenna, module pins 2 are for 2G/BT/5G signal (Note 1), module pins 9 and 47 are NC.

Option 2: 2.4G/5G uses dual antennas, module pin 9 is for 5G signal (Note 2), module pin 47 is for 2G/BT signal (Note 3), module pin 2 is NC.

Additionally, GNSS uses a separate antenna. Module pin 45 connects to an external GNSS antenna (Note 4).

## Note: Module Power Supply Instructions

1. VBAT Input voltage range: 3.5~4.5V. Recommended voltage: 3.7V. **Current: 1A.**
2. VDDIO only supports 1.8V. **Current: 200mA.**
3. 5GPA\_5V is the power supply for 5G FEM. **Current: 380mA. 5GPA can also be powered by 3.3V, but the output power of 5G will be about 3dB lower compared to 5V supply. When 5GPA is powered by 3.3V, the current is 310mA.**

## Note: About the clock instructions.

1. The module comes with a default 38.4MHz clock crystal oscillator. It can also be selected from the input at pin 33 of the module. If using the 38.4M clock on the module, leave pin 33 of the module floating.
2. Pin 31 must be externally connected to an RTC clock of 32.768KHz  $\pm 20$ ppm, with an amplitude of 0.9 to 1.8V, in the form of a square wave or sine wave. This will be used for power-on detection.

## 3 RF Performance

### 3.1 WiFi 2.4G Transmitter Performance

Parameter	Test Item	Typical Value	CH1	CH7	CH13	Unit
<b>2.4G Output Power</b>	11b,CCK, 1Mbps	23±1dBm,EVM<-19dB	23	23	23	dBm
	11b,CCK,11Mbps	23±1dBm,EVM<-15dB	23	23	23	dBm
	11g,OFDM, 6Mbps	20±1dBm,EVM<-26dB	20	20	20	dBm
	11g,OFDM,54Mbps	20±1dBm,EVM<-30dB	20	20	20	dBm
	11n, HT20 MCS0	20±1dBm,EVM<-26dB	20	20	20	dBm
	11n, HT20 MCS7	20±1dBm,EVM<-32dB	20	20	20	dBm
	Test Item	Typical Value	CH3	CH7	CH11	Unit
	11n, HT40 MCS0	20±1dBm,EVM<-26dB	20	20	20	dBm
	11n, HT40 MCS7	20±1dBm,EVM<-31dB	20	20	20	dBm

### 3.2 WiFi 2.4G Receiver Performance

Parameters	Test Item	CH1	CH7	CH13	Unit
<b>2.4G Receive Sensitivity</b>	11b, CCK,1M , <-83dBm@8%PER	-99	-99	-99	dBm
	11b,CCK, 11M ,<-76dBm@8%PER	-90	-90	-90	dBm
	11g, OFDM,6M , <-82dBm@10%PER	-95	-95	-95	dBm
	11g, OFDM,54M , <-65dBm@10%PER	-78	-78	-78	dBm
	11n, HT20 MCS0, <-82dBm@10%PER	-94	-94	-94	dBm
	11n, HT20 MCS7, <-64dBm@10%PER	-76	-76	-76	dBm
	Test Item	CH3	CH7	CH11	Unit
	11n, HT40 MCS0,<-82dBm@10%PER	-91	-91	-91	dBm
	11n, HT40 MCS7,<-64dBm@10%PER	-73	-73	-73	dBm

# S102 WiFi / BT / GNSS Module

## 3.3 WiFi 5G Transmitter Performance

Parameter	Test Item	Typical Value	CH36	CH100	CH165	Unit
5G Output Power	11a,OFDM,6Mbps	25±2dBm,EVM<-20dB	25	25	25	dBm
	11a,OFDM,54Mbps	21±2dBm,EVM<-27dB	21	21	21	dBm
	11n, HT20 MCS0	25±2dBm,EVM<-20dB	25	25	25	dBm
	11n, HT20 MCS7	21±2dBm,EVM<-29dB	21	21	21	dBm
	11ac, VHT20 MCS0	23±2dBm,EVM<-20dB	23	23	23	dBm
	11ac, VHT20 MCS8	20±2dBm,EVM<-30dB	20	20	20	dBm
	Test Item	Typical Value	CH38	CH110	CH159	Unit
	11n, HT40 MCS0	25±2dBm,EVM<-21dB	25	25	25	dBm
	11n, HT40 MCS7	21±2dBm,EVM<-30dB	21	21	21	dBm
	11ac, VHT40 MCS0	23±2dBm,EVM<-20dB	23	23	23	dBm
	11ac, VHT40 MCS9	20±2dBm,EVM<-32dB	20	20	20	dBm
	Test Item	Typical Value	CH58	CH122	CH155	Unit
	11ac, VHT80 MCS0	23±2dBm,EVM<-20dB	23	23	23	dBm
	11ac, VHT80 MCS9	20±2dBm,EVM<-32dB	20	20	20	dBm

## 3.4 WiFi 5G Receiver Performance

Parameters	Test Item	CH36	CH100	CH165	Unit
5G Receive Sensitivity	11a, OFDM,6M , <-82dBm@10%PER	-94	-94	-94	dBm
	11a, OFDM,54M , <-65dBm@10%PER	-78	-78	-78	dBm
	11n, HT20 MCS0, <-82dBm@10%PER	-93	-93	-93	dBm
	11n, HT20 MCS7, <-64dBm@10%PER	-75	-75	-75	dBm
	11ac, VHT20 MCS0, <-82dBm@10%PER	-91	-91	-91	dBm
	11ac, VHT20 MCS8, <-64dBm@10%PER	-73	-73	-73	dBm
	Test Item	CH38	CH110	CH159	Unit
	11n, HT40 MCS0,<-79dBm@10%PER	-90	-90	-90	dBm
	11n, HT40 MCS7,<-61dBm@10%PER	-72	-72	-72	dBm
	11ac, VHT40 MCS0,<-79dBm@10%PER	-90	-90	-90	dBm
	11ac, VHT40 MCS9,<-61dBm@10%PER	-67	-67	-67	dBm
	Test Item	CH58	CH122	CH155	Unit
	11ac, VHT80 MCS0,<-79dBm@10%PER	-88	-88	-88	dBm
	11ac, VHT80 MCS9,<-61dBm@10%PER	-64	-64	-64	dBm

# S102 WiFi / BT / GNSS Module

## 3.5 BT/BLE TX Performance

Parameter	Test Item	Typical Value	Channel			Unit
			CH0	CH19	CH39	
Output power	BT	14±1	14	14	14	dBm
	BLE	14±1	14	14	14	dBm

## 3.6 BT/BLE RX Performance

Parameter	Test Item	Typical Value	Channel			Unit
			CH0	CH19	CH39	
Sensitivity >30% packet	BT	<-90	-95	-95	-95	dBm
	BLE	<-88	-96	-96	-96	dBm

## 3.7 GNSS Receiver Performance

Parameters	Test Item	MIN	TYPE	MAX	Unit
GNSS Receive Sensitivity	GPS capture sensitivity	-	-150	-	dBm
	GLONASS capture sensitivity	-	-148	-	dBm
	Beidou capture sensitivity	-	-146	-	dBm
	Test Item	MIN	TYPE	MAX	Unit
	GPS capture sensitivity	-	-163	-	dBm
	GLONASS capture sensitivity	-	-160	-	dBm
	Beidou capture sensitivity	-	-158	-	dBm

## 4 Lead-free reflow soldering process parameter requirements

The lead-free reflow soldering process curve is shown in the following figure.

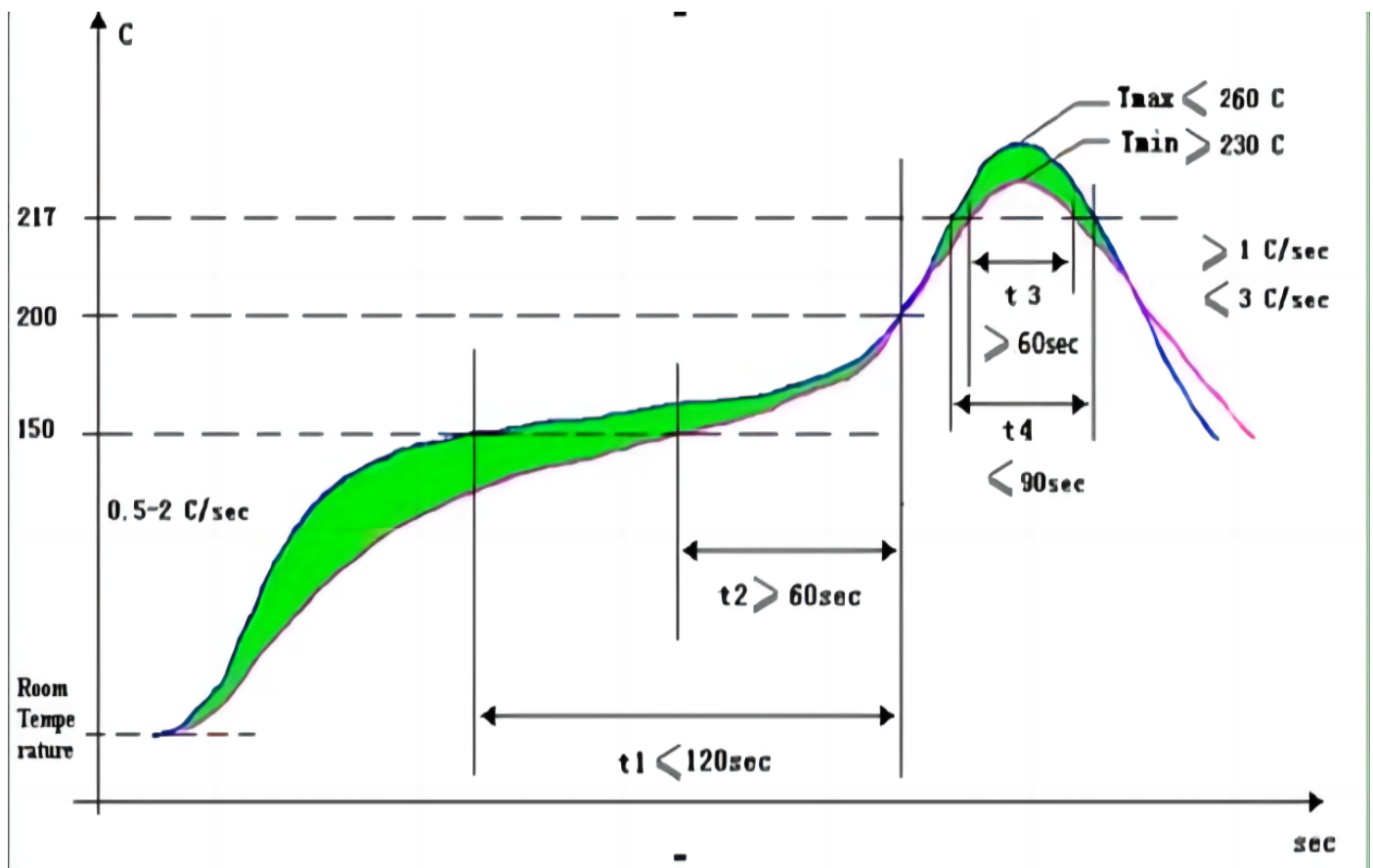



## S102 WiFi / BT / GNSS Module

The lead-free reflow soldering process parameters are shown in the table below.

Zones	Time	Heating rate	Peak temp	Rate of temperature drop
preheating(40 ~ 150°C)	60 ~ 150s	≤2.0°C/s	-	-
heating(150 ~ 200°C)	60 ~ 120s	< 1.0°C/s	-	-
reflow(> 217°C)	60 ~ 90s	-	230-260°C	-
cooling(Tmax ~ 180°C)	-	-	-	1.0°C/s≤Slope≤4.0°C/s

Explanation:

- The reflow soldering curve provided is for reference only, and the client needs to make corresponding adjustments according to the actual production situation.

The temperature resistance standard of the package body refers to the IPC/JEDEC J-STD-020D standard, and the temperature measurement method of the package body refers to the JEP 140 standard.

According to the IPC/JEDEC J-STD-020D standard, the package body temperature measurement method follows the requirements of the JEP 140 standard.

The lead-free device package body temperature resistance standards in IPC/JEDEC 020D are shown in the table below.

Package Thickness	Volume mm <sup>3</sup> <350	Volume mm <sup>3</sup> 350~2000	Volume mm <sup>3</sup> >2000
< 1.6mm	260°C	260°C	260°C
1.6mm ~ 2.5mm	260°C	250°C	245°C
> 2.5mm	250°C	245°C	245°C

## 5 Order Information

Modul	Part number	Description
S102	S102_1A_NG_NS	S102WiFi/BT single antenna output, Without GNSS,without shielding cover
S102	S102_2A_NG_NS	S102WiFi/BT dual antenna output,Without GNSS,without shielding cover
S102	S102_1A_WG_NS	S102WiFi/BT single antenna output,With GNSS,without shielding cover
S102	S102_2A_WG_NS	S102WiFi/BT dual antenna output,With GNSS,without shielding cover
S102	S102_1A_NG_WS	S102WiFi/BT single antenna output,Without GNSS,with shielding cover
S102	S102_2A_NG_WS	S102WiFi/BT dual antenna output,Without GNSS,with shielding cover
S102	S102_1A_WG_WS	S102WiFi/BT single antenna output,With GNSS,with shielding cover
S102	S102_2A_WG_WS	S102WiFi/BT dual antenna output,With GNSS,with shielding cover

Note: GNSS uses an independent receiving antenna.